

Wood chipper

QUESTION - CAN A PERSON BE INJURED?	HAZARD (YES / NO)	WHAT IS THE HAZARD?	WHAT IS THE CONTROL?
A. ENTANGLEMENT			
1. Can anybody's hair, clothing, gloves, necktie, jewellery, cleaning brushes, rags or other materials become entangled with moving parts of the plant, or materials in motion?	YES	Carelessness putting brushes, rags etc. into the hopper.	Common sense. Clear hopper prior to start up. Wear proper PPE.
B. CRUSHING			
1. Can anybody be crushed due to:			
a. Uncontrolled or unexpected moving of the plant or its load?	YES	Unit with jockey wheel down. Mobile.	Common sense. Block wheels prior to use.
b. The plant tipping or rolling over?	YES	Steep angle of bank, drop drive wheel in hole.	Common sense. Leave on tow ball when pulling plant.
c. Coming in contact with moving parts of the plant during testing, inspection and operation?	YES	If done while machine is running.	TAKE CARE! Do not perform while machine is running.
d. Other factors not mentioned?	YES		Spectators must be kept away.
C. CUTTING, STABBING, PUNCTURING OR STRIKING?			
1. Can anyone be cut, stabbed or punctured due to:			
a. Coming in contact with sharp or flying objects?	YES	Leave guards in place.	Only stand in operator zone. Wear eye protection
b. Coming in contact with moving parts of the plant during testing, inspection and operation?	YES	If engine running and one engages wheel drive lever or blade lever.	Instruction of individual as to how the machine functions. Guards in place. Stay in operator's zone.
c. The plant, parts of the plant or work pieces disintegrating?	YES	Flying object due to misuse or if escape past guards / flap.	Stay in operator's zone. Feed only wood into the machine.
d. Work pieces being ejected?	YES	If escape past guards / flap.	Wear proper safety gear. Shut machine down.
D. FRICTION			
Can anyone be burnt due to contact with moving parts or surfaces of the plant, or between a part of the plant and a work piece or structure?	YES	Engine exhaust.	Instruction of operator. Muffler area protected. Wear proper safety clothing.
E. EXPLOSION			
1. Can anyone be injured by explosion of gases, vapours, liquids, dusts or other substances, triggered by the operation of the plant or by material handled by the plant?	YES	Fuel tank explosion.	Use only outside.

F. SLIPPING, TRIPPING & FALLINGS

1. Can anyone using the plant, or in the vicinity of the plant, slip, trip or fall due to:

a. Uneven or slippery work surfaces?	YES	Assumed risk.	Common sense, supervision.
b. Poor housekeeping: e.g. swarf in the vicinity or the plant spillage not cleaned up?	YES	Human error.	Common sense, supervision.
c. Obstacles being placed in the vicinity of the plant, other factors not mentioned?	YES	Human error.	Common sense, supervision.

G. OTHER HAZARDS

1. Can anyone be injured or suffer ill health from exposure to:

a. Fumes and dust?	YES	Gas fumes operation in confined area.	Use outside only. Wear safety mask.
b. Noise?	YES	No PPE.	Wear ear protection.

MANDATORY PERSONAL PROTECTIVE EQUIPMENT

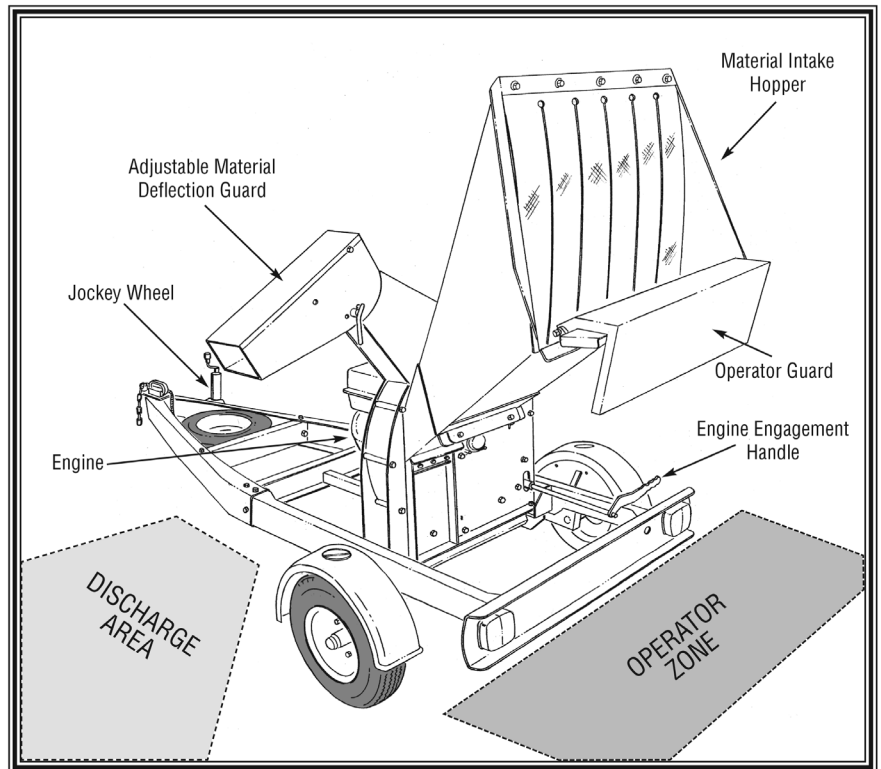

Customer Signature: _____ Date: _____