

Excavator 1.6 ton (TB216)

TECHNICAL DATA

Engine	
Make	YANMAR
Model	3TNV70
Rated output (kW)/rpm	11.5/2400
Maximum torque (Nm)	51.8
Cylinders	3
Displacement (cc)	854
Electrical system	12V
Dimensions & weight	
Operating weight inclusive of bucket and fuel: canopy (kg)	1680
Overall length (mm)	3870
Width canopy (mm)	990
with extended track	1300
Height canopy (mm)	2280
Ground clearance (mm)	205
Min. front swing radius (mm)	1155
Tail swing radius (mm)	1075
Dozer blade (w x h) (mm)	900/1300 x 310
Operating information	
Max digging depth (mm)	2390
Max dump height (mm)	2705
Max reach at ground level (mm)	4035
Max vertical digging depth (mm)	2060
Max bucket digging force (kN)	14
Max arm digging force (kN)	8.2
Hydraulic system	
Set pressure (bar)	210
Pump type	Variable
Hydraulic flow aux port (l/min)	33
Swing system	
Boom swing angle (R/L)	50°/80°
Slew speed (rpm)	9.2
Undercarriage	
Traction motor	Piston
Traction drive	Epicyclic Gearing
Traction brake	Friction brake
Track width (mm)	230
Ground contact length (mm)	1155
Ground pressure (kpa)	31/29.4
Travel speed (km/h)	2.2-4.2
Maximum gradeability	15°
Capacities	
Hydraulic system (l)	24.5
Fuel tank (l)	22
Engine lubrication (l)	2.8
Cooling system (l)	3.8

All dimensions unless otherwise stated are in millimetres.

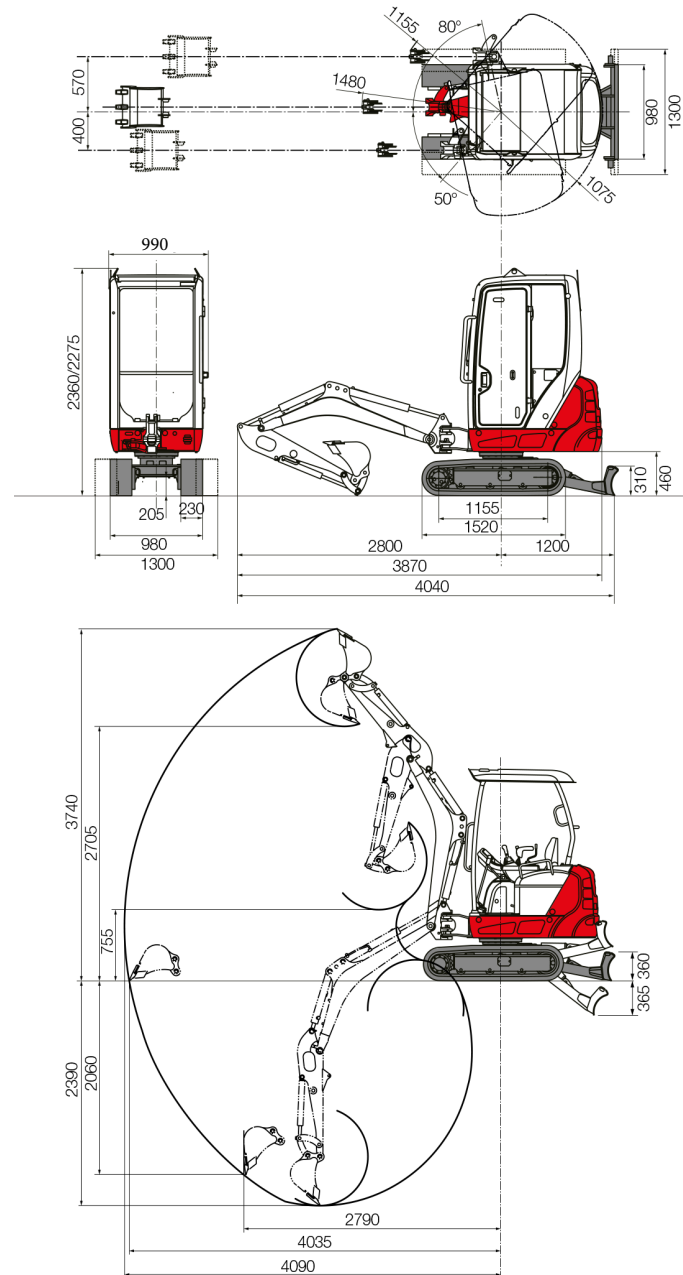

OPERATION

- Added offset position RH 80° and LH 50°
- Cushioned main boom and swing cylinders for smooth operation
- Boom and cab mounted work light give options for all types of working conditions
- Well-positioned enhanced VDU - warning indicators, rpm, hour meter, fuel, battery charge, temperature, oil pressures and maintenance alerts.

OPTIONS

- Breaker
- Auger
- Quick Hitch
- Bucket sizes from 150-1000mm

When service matters.
hiredepot.com.au

GLEN IRIS
 70 High St
 9885 4431

FAIRFIELD
 323 Darebin Rd
 9499 9955