

Product features & specifications

ENGINE	
Piston displacement	1632cc
Rated power / r.p.m	22/2400kw
Rated torque / r.p.m	106/1000Nm
CONTROLS	
Steering	Forward, reverse, variable speed, two hand lever
Drive	Two Hydrostatic Transmissions with infinitely variable speed
FUEL	
Fuel capacity (litres)	35
PERFORMANCE	
Tipping load (SAE)	860kg
Operating load (SAE)	430kg
Ground clearance (centre)	231mm
Machine weight (with fuel and std bucket)	1865kg
Dump height (dump angle 40°)	2120mm
Reach fully raised (dump angle 40°)	490mm
Dump angle (max)	40deg
Raising time (full load)	4.0sec
Lowering time (no load)	2.7sec
Dump time	2.4sec
Travel speed (forward)	11.0km/h
Travel speed (reverse)	11.0km/h
Clearance circle (with bucket)	1700mm
Gradeability (forward)	30%
Gradeability (reverse)	57%

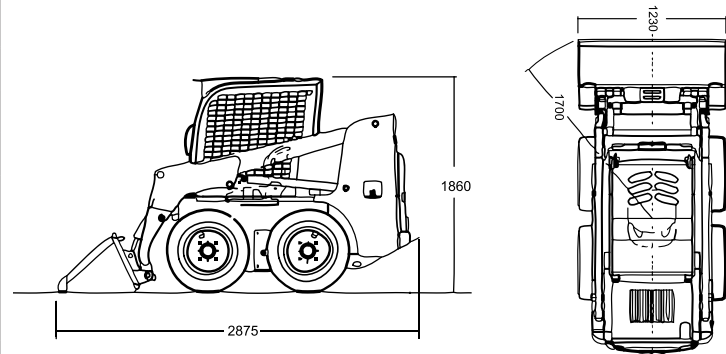

ALSO REFER TO:

1. Bobcat hazard assessment sheet
2. Bobcat operating procedure

RELATED ITEMS

- Post hole digger - 1 man
- Excavator with post hole digger
- Dingo with post hole digger
- Post hole digger - 2 man
- Post hole digger - manual
- Manual post hole cleaner
- Dingo with trencher
- Chain trencher
- Rock breaker
- Excavator 1.6 ton
- Dingo
- Motorised wheelbarrow "muck truck"
- Trencher