

TB108 EXCAVATOR

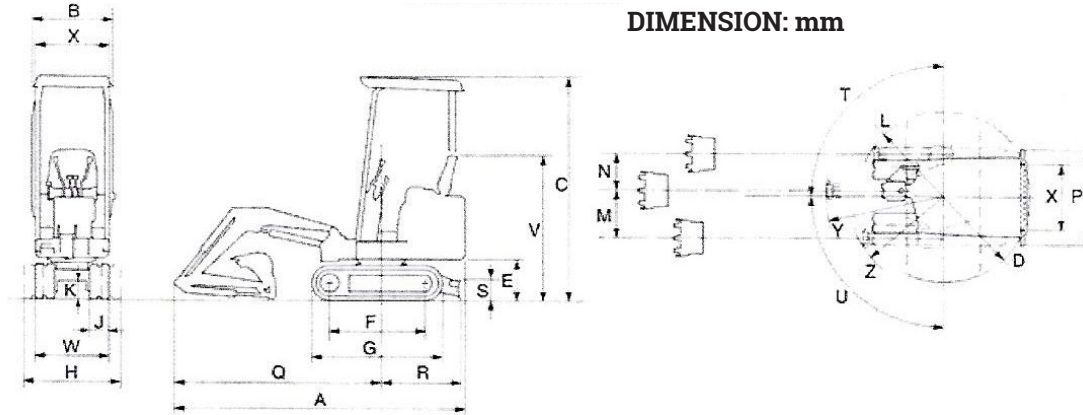

A	2710
B	740
C	2110 / 2195
D	800
E	385
F	900
G	1220
H	900
J	180
K	160
L	790
M	440
N	340
P	900
Q	1920
R	740
S	200
T	90°
U	90°
V	1375
W	680
X	680
Y	1080
Z	880

Units: mm

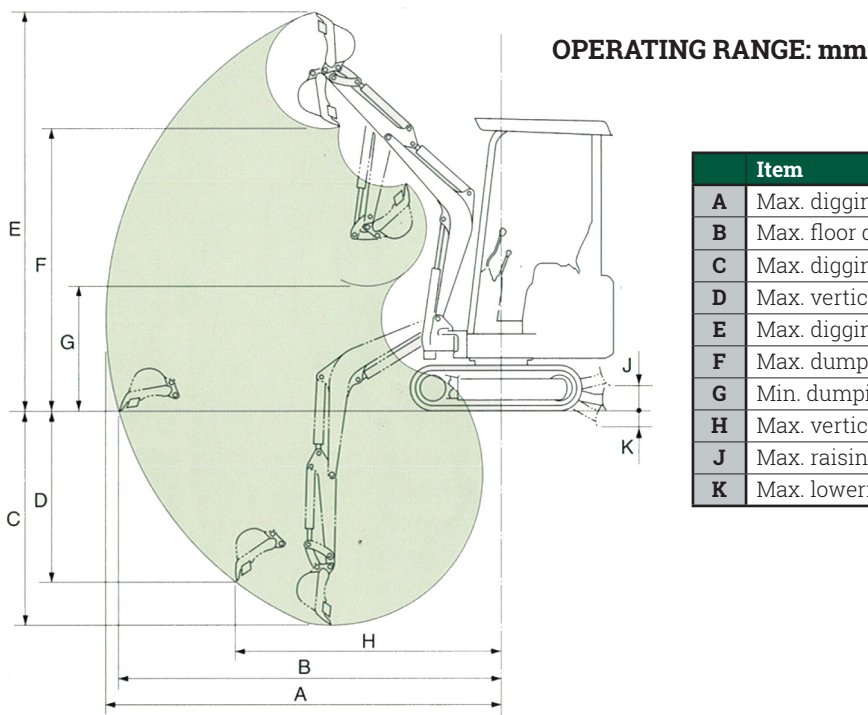

Item	Standard arm	Long arm	
A	Max. digging radius	2825	2970
B	Max. floor digging radius	2730	2880
C	Max. digging depth	1530	1680
D	Max. vertical digging depth	1220	1370
E	Max. digging height	2860	2975
F	Max. dumping height	2030	2145
G	Min. dumping height	900	760
H	Max. vertical digging radius	1890	1915
J	Max. raising height	155	<---
K	Max. lowering depth	120	<---

ALSO REFER TO:

1. Excavator hazard assessment sheet
2. Excavator operating procedure

RELATED ITEMS

- Post hole digger - 1 man
- Excavator with post hole digger
- Dingo with post hole digger
- Post hole digger - 2 man
- Post hole digger - manual
- Manual post hole cleaner
- Dingo with trencher
- Chain trencher
- Rock breaker
- Excavator 1.6 ton
- Excavator 3.5 ton
- Dingo
- Motorised wheelbarrow "muck truck"
- Trencher
- Excavator 1.6 ton

TB108 EXCAVATOR

SPECIFICATIONS TB108

(canopy, rubber tracked, breaker pipings standard, fops / tops canopy, standard arm)

Weight		Performance		Max. dig height	2860
Machine weight (kg)	855	Traction speed (km/h)	2.0 / 3.9	Max. dig radius	2825
Bucket		Upper slew speed (min ⁻¹)	93	Max. floor dig radius	2730
Bucket capa (m ³)	0.013 (struck) / 0.018 (heaped)	Gradeability (deg / %)	25° / 47%	Min. slew radius	790
Bucket width (mm)	350	Max dig power bucket (kN)	10.2	Max. bucket offset RH / LH	340 / 440
Diesel Engine (water-cooled)		Max dig power arm (kN)	6.6	Hydraulic system	
Model	2TNV70	Ground press (kPa)	25.1	Pump type	2 gear
Type	2CYL. 4CYCL	Dozer blade: mm		Pump pressure (MPa)	15.7x2
Rated output (kW)	7.1 / 2,400min	Width x height	680 x 200	Hydraulic motor type	Orbit
Max torque (N m)	33	Operating range up / down	155 x 120	Hydraulic oil discharge (L/min)	10.7x2
Displacement (mL)	569	Off-set dig function		Auxiliary flow (L/min)	21.4
Cool water capa. (L)	2.8	Type	Boom swing	Hydraulic oil filter type	Hybrid filter
Lub. oil capa (L)	1.7	Swing angle RH / LH	90° / 90°	Hydraulic tank capa	8
Fuel tank capa (L)	9.4	Traction system: mm			
Overall dimension: mm		Crawler type	Rubber track		
Length (in transport)	2710	Crawler shoe width	180		
Width	740	Operating range: mm			
Height	2110	Max digging depth	1530		
Rear slew radius	800	Max. vertical dig depth	1220		
Min. ground clearance	160	Max. dump height	2030		

When service matters.
hiredepot.com.au

GLEN IRIS
 70 High St
 9885 4431

FAIRFIELD
 323 Darebin Rd
 9499 9955