

Product features & specifications

OPERATING PERFORMANCE	
Operating weight - canopy	3465kg
Operating weight - cab	3605kg
BUCKET	
Bucket capacity (heaped) m ³	0.105 (heaped)
Bucket width mm	540
DIESEL ENGINE (WATER-COOLED)	
Model	3TNV88
Cylinders / type	3/4CYCL
Engine power: kW (ISO 9249)	21.5/2400 min-1
Engine power: kW (ISO 14396)	22.2/2400 min-1
Engine power: kW (SAE J1995)	22.5/2400 min-1
Maximum torque (N.m)	98.6-107.4
Displacement (mL)	1642
Engine coolant (L)	8.7
Engine oil (L)	4.7
Fuel tank (L)	52.5
Electric system	12V/40A
PERFORMANCE	
Traction speed (km/h)	26 / 5.0
Upper slew speed (min-1)	10.2
Gradeability (degrees)	30°
Max dig power bucket (kN)	27
Max dig power arm (kN)	SSA: 18.3 MSA: 17.1 LSA: 16.0
Ground pressure (kPa) - canopy	26.8
Ground pressure (kPa) - cabin	27.9

OFF-SET DIG FUNCTION	
Type	Boom swing
TRACTION SYSTEM	
Type	Rubber / steel
HYDRAULIC SYSTEM	
Pump type	Variable x 2 + Gear x 2
Set pressure (MPa)	21.0 x 2 + 19.6 x 1 + 3.4 x 1
Discharge (L/min)	38.9 x 2 + 22.8 x 1 + 10.8 x 1
Slew motor	Piston motor
Traction motor	2-speed piston motor
Hydraulic oil capacity	35 (level) / 67 (system)
SAFETY	
ROPS / FOPS (Cabin / canopy)	ROPS / FOPS
OPTION & EQUIPMENTS	
Service Port 1 L/min/MPa	61.7 / 21.0 (standard)
Service Port 2 L/min/MPa	22.8 / 19.6 (option)
Service Port 3 Flow Rate (A/B) L/min	10.8 / 38.9 (option)
Service Port 3 Pressure (A/B) MPa	3.4 / 19.6 (option)
Ground pressure (kPa) - cabin	27.9
VIBRATION LEVELS (EN 12096:1997)	
Hand / arm	≦ 2.5m/s ²
Body	≦ 0.5m/s ²

ALSO REFER TO:

1. Excavator hazard assessment sheet
2. Excavator operating procedure

RELATED ITEMS

- Post hole digger - 1 man
- Excavator with post hole digger
- Dingo with post hole digger
- Post hole digger - 2 man
- Post hole digger - manual
- Manual post hole cleaner
- Dingo with trencher
- Chain trencher
- Rock breaker
- Excavator 1.6 ton
- Dingo
- Motorised wheelbarrow "muck truck"
- Trencher

TB235 EXCAVATOR (3.5 TON)

OPERATING RANGES:mm

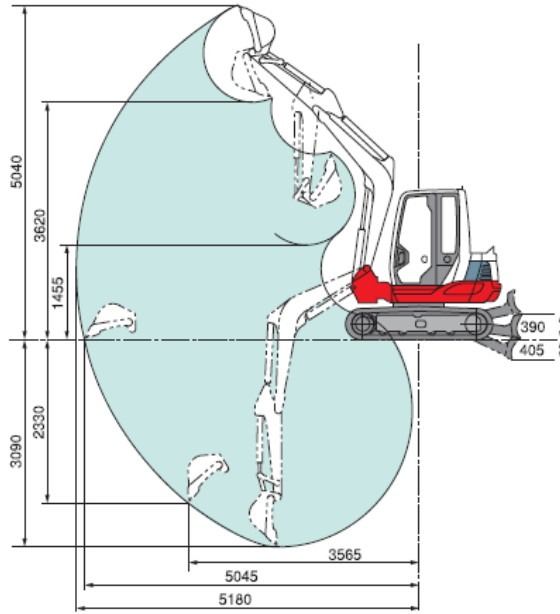

MACHINE DIMENSIONS:mm

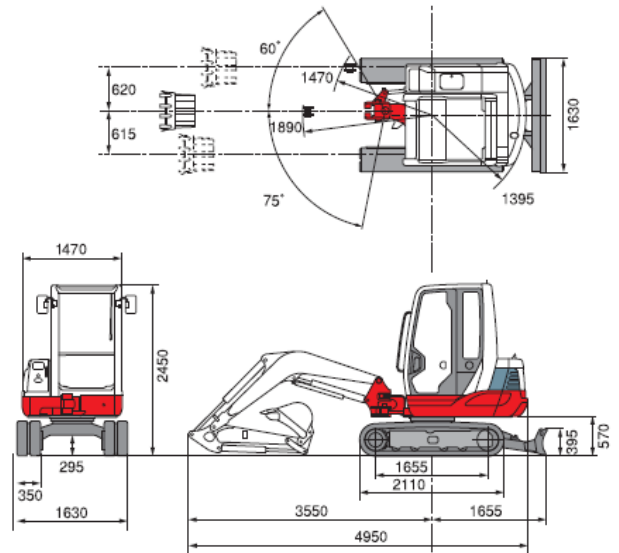

MACHINE DIMENSIONS

A	Maximum reach	5180mm
B	Maximum reach at ground level	5045mm
C	Maximum digging depth	3090mm
D	Maximum vertical digging depth	2330mm
E	Maximum dig height	5040mm
F	Maximum dumping height	3620mm
G	Front swing radius	1950mm
H	Front swing radius with boom offset	1535mm
I	Tail swing (slew) radius	1395mm
J	Transport length	4900mm
K	Transport height	2450mm
L	Ground clearance	295mm
M	Undercarriage length	2110mm
N	Track width (rubber)	350mm
O	Undercarriage width	1630mm

When service matters.
hiredepot.com.au

GLEN IRIS
 70 High St
 9885 4431

FAIRFIELD
 323 Darebin Rd
 9499 9955