

Dehumidifier

(Guide only)

IMPORTANT INSTRUCTIONS

WARNING: To reduce the risk of fire, electrical shock or injury to persons or property:

1. Always operate the product from a power source of the same voltage, frequency and rating as indicated on the product identification plate.
2. Close supervision is necessary when any product is used by or near children, the elderly or the infirm. Do not allow children to use this appliance as a toy.
3. Do not operate this product with a damaged power cord plug. If the supply cord is damaged it must be replaced by qualified personnel or other similar qualified persons in order to avoid hazard.
4. To reduce the risk of electric shock, do not expose the unit or flexible cord to moisture of any kind.
5. Switch off and unplug from the power socket when not in use, before assembling and before cleaning.
6. Do not place objects on the product or allow objects to obstruct the inlet or outlet openings, or operate in close proximity to walls or curtains, etc.
7. The use of attachments or accessories not recommended or sold by the product distributor may cause injury to persons or damage to property.
8. This product is intended for normal, light commercial use only.
9. Do not attempt to dismantle the appliance.
10. Do not operate the appliance on a metal surface.
11. Do not use the appliance in artificially hot or humid conditions, or allow to be used in a hazardous environment.
12. Do not clean the appliance with organic solvent.
13. This appliance is not intended for use by persons (including children) with reduced physical, sensory or mental capabilities, or lack of experience and knowledge, unless they have been given supervision or instruction concerning use of the appliance by a person responsible for their safety.
14. Children should not be left unsupervised with the appliance.
15. This instruction manual is an integral part of the appliance and should be stored for safe keeping. It must always accompany the appliance in the event of ownership transfer or for reference to by a service engineer.

READ AND SAVE THESE SAFETY INSTRUCTIONS

PRODUCT IDENTIFICATION

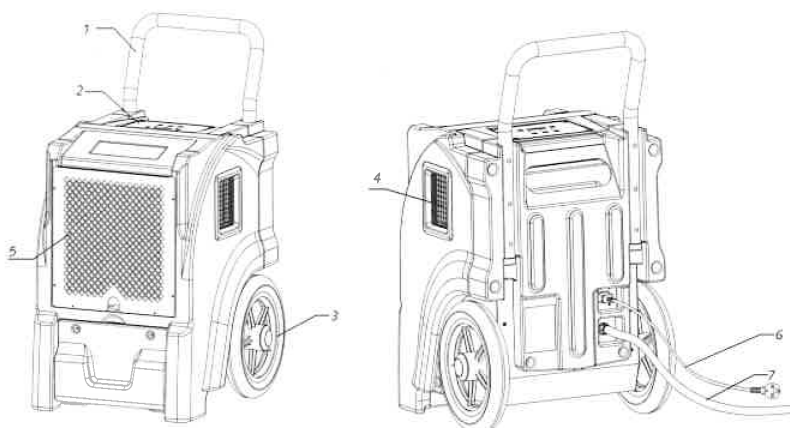

1. Metal handle
2. Control panel
3. Wheels
4. Air outlet grille
5. Air inlet grille
6. Power cord
7. Water pipe

WARNING
DO NOT OBSTRUCT THE
AIR INLET OR OUTLET

SETUP INSTRUCTIONS

IMPORTANT

Place dehumidifier in the upright position. When transporting a dehumidifier to site, allow the dehumidifier to stand for 30 minutes before switching ON. This is necessary to allow the refrigerant system to stabilise and avoid system damage.

SETTING UP THE DEHUMIDIFIER

Operate the dehumidifier in an enclosed area, as this creates a drying chamber. Close all doors, windows or areas that open to external areas, to maximise the dehumidifier's water removal efficiency. Keep traffic through the drying chamber to a minimum. Place the dehumidifier in the centre of the room away from walls and furnishings. **DO NOT** allow the airflows to be obstructed.

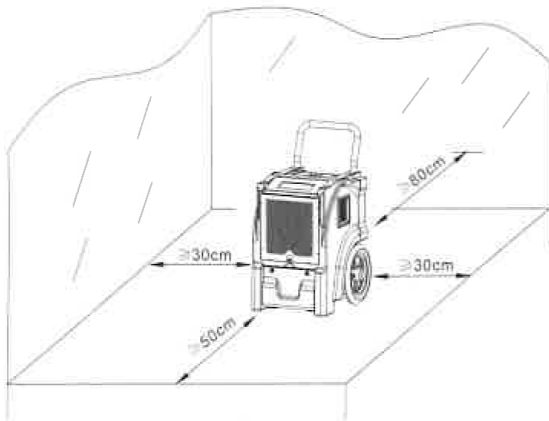

Illustration of correct positioning for best performance.

DRAINAGE

The dehumidifier pump connects to a plastic drainage hose. The hose is stored on the back of the appliance. Uncoil the entire hose ensuring there are no kinks or restrictions and place the unattached end into a water vessel or run to outdoors.

Ensure that water that runs to outdoors does **NOT** create a slip hazard.

Water vessels **MUST** be checked regularly where used.

SET UP INSTRUCTIONS

The position of the drain water pipe should not be too high (<4.5 metres). Failure to do so may cause a water backup in the pump, resulting in leakage.

When turning off the unit, please take out the water pipe and empty water inside bucket to avoid the water backflow causing water leakage.

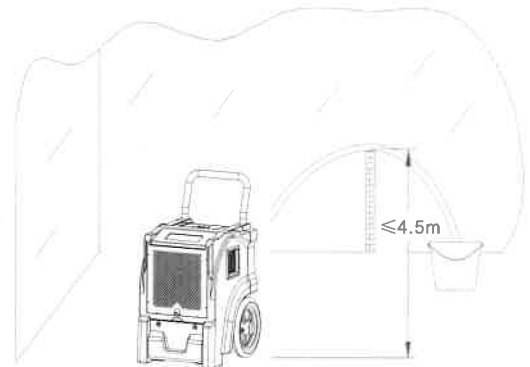

CONTROL PANEL

1. ON / OFF key
2. UP / DOWN key
3. Purging indicator
4. Defrosting indicator
5. PURGE key
6. HUMIDITY AND TIME display
7. TIME key
8. Operating indicator

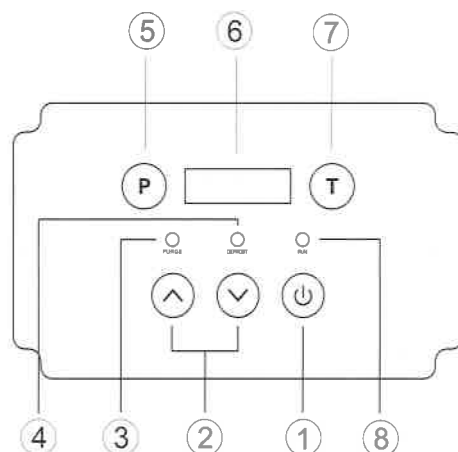

- A. **⏻ ON / OFF:** Press the ON / OFF key to turn the unit ON or OFF.
- B. **Ⓟ PURGE:** Press the PURGE key to empty water from the pump reservoir. During normal operation the pump purges automatically when the reservoir is full. Use 'PURGE' before moving the machine to avoid water spillage. The pump will close automatically after forty seconds of continuous operation.
- C. **⬆️ ⬆️** Press the UP and DOWN keys to set or adjust humidity in the range between 26% and 90%. When the environmental humidity is below 26% "CO" will be displayed.
- D. **Ⓣ TIME:** Display working hours and total working time after turning on the unit. It can display humidity (left) and current humidity (right) settings, and humidity can be changed by pressing 'up' and 'down'. For example, for the current time (time unit is based on minutes), '0000:50' is displayed this means that the unit has been in operation for 50 minutes. If you want to view the total working time, press the 'T' again and the total working time will be displayed for 10 seconds, before returning automatically to the to the original working hours. If you press 'T' before the 10 seconds have passed, it will default to the original working hours.

If the unit is powered on but not in operation, the LED will display nothing. In this condition, the working hours from the previous operation will be displayed for 10 seconds if 'T' is pressed once. However, if 'T' is pressed again within 10 seconds, the total working time will be displayed for 10 seconds. If there is no further action within 10 seconds, the LED will automatically shut down. Further, if 'T' is pressed again when LED displays the total working time, the LED will shut down immediately. The current working time will be deleted by holding 'T' continuously for 5 seconds and the time will be recounted. Note that the deleted time will be included in the total working time.

- E. **DEFROST INDICATOR:** The unit begins to defrost when the defrost indicator lights up and will stop defrosting when the defrost indicator is off. When the defrosting process is complete, the unit will begin to dehumidify automatically again.

NOTE: The total working time cannot be deleted. If the time is beyond the range of the LED display time, it will be deleted and recount from the start.

OPERATING INSTRUCTIONS

A. OPERATION FOR GENERAL USE

1. Press the ON / OFF key to turn the unit on. It will enter working mode automatically.
2. After use, press the ON / OFF key to turn off the unit. The water pump will turn on automatically for 40 seconds to drain the remainder of the water and then switch off automatically.

ATTENTION

DO NOT switch the power OFF by disconnecting at the mains outlet socket. To avoid water spillage, DO NOT move the dehumidifier for at least three minutes after turning the power OFF.

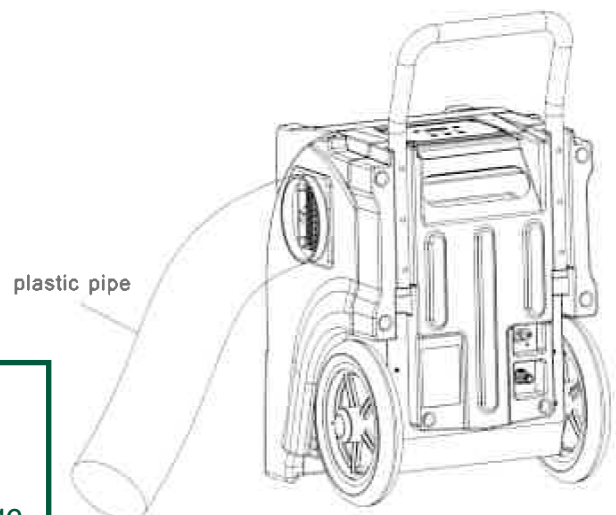

B. KEY LOCK FUNCTION

If the 'T' and 'PURGE' keys are held for 2 seconds at the same time, the operating light will display a speed of 50Hz and all keys on the control panel will be locked. Performing the same action again will unlock.

B. PIPE FUNCTION

For a much wetter space, use a plastic pipe with a diameter larger than 150mm. Tie the pipe to the hood as it will dry faster and more effectively.

Do not under any circumstances attempt any repairs. Please call your local Hiredepot branch for assistance.

This operating and safety brochure is intended as a guide only for the safe operation of this equipment. It does not override license requirements nor is it a substitute for structured operating lesson. If you are unsure about any aspect of the equipment, its capabilities or the correct usage, please call our trained staff for instruction or any questions you may have regarding the safe operation of this equipment.

When service matters.
hiredepot.com.au

GLEN IRIS
70 High St
9885 4431

FAIRFIELD
323 Darebin Rd
9499 9955